

REV	DATE	DESCRIPTION	ECO	BY	C'H'K.
AJ	09/15/2015 00:00:00 AM	ROLLMARKING DETAILS UPDATED	41819	NG	RG

CATALOG NUMBER	CONDUCTOR SIZE		CONNECTOR DIMENSIONS-LINEAR MEASURE IN, [mm]										INFORMATION	BARREL LETTERING INFORMATION
	ALUMINUM	COPPER	STUD SIZE	NO. OF HOLES	B	C	D	Ø K	L	N	O.D	(T)		
YA6CA1	6 AWG CLASS B CONCENTRIC COMPRESSED	6 AWG CLASS B,C CONCENTRIC COMPRESSED	1/4	1	.75 [19]	.47 [12]	.75 [19]	.28 [7]	1.84 [47]	.33 [8]	.34 [9]	.14 [4]	TIN	FIG. 2
YA6CA2	CONCENTRIC COMPRESSED	COMPRESSED	3/8		.75 [19]	.65 [17]	1.19 [30]	.44 [11]	2.28 [58]	.44 [11]		.09 [2]	NONE	FIG. 1
YA6CA3	COMPACT	COMPACT			TIN	FIG. 2								
YA6CA4	SIW		NONE		FIG. 1									

COLOR CODE	BURNDY® INSTALLATION TOOLING (#CRIMPS)										DIELESS (#CRIMPS)		STRIP LENGTH
	DIE INFORMATION		MECHANICAL		HYDRAULIC						MECHANICAL	HYDRAULIC	
	DIE INDEX	TYPE	OUR840	MD6	Y34A Y34B	Y35, Y39 Y750, PAT750	Y46	Y45	Y48BH	Y60			
GRAY	346 161	GRAY DIE SET	X6CART (2) X161 (2)	X6CART (2) W161 (1)	A6CAB (1)	U6CABT (1) U161 (1)	U6CABT (1) U161 (1)	U6CABT (1) U161 (1)	--	--	MRC840AL (1) MY29-3 (1)	Y81KFT (1) PAT81KFT (1) Y644 (1) PAT644 (1)	7/8"
	346	NEST INDENTOR	--	--	A4CD(1) B1CD(1) Y34PA	--	--	--	--	--			

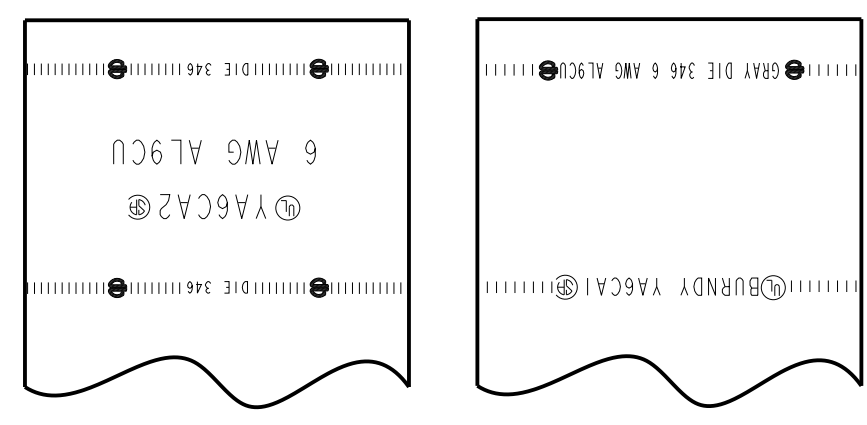
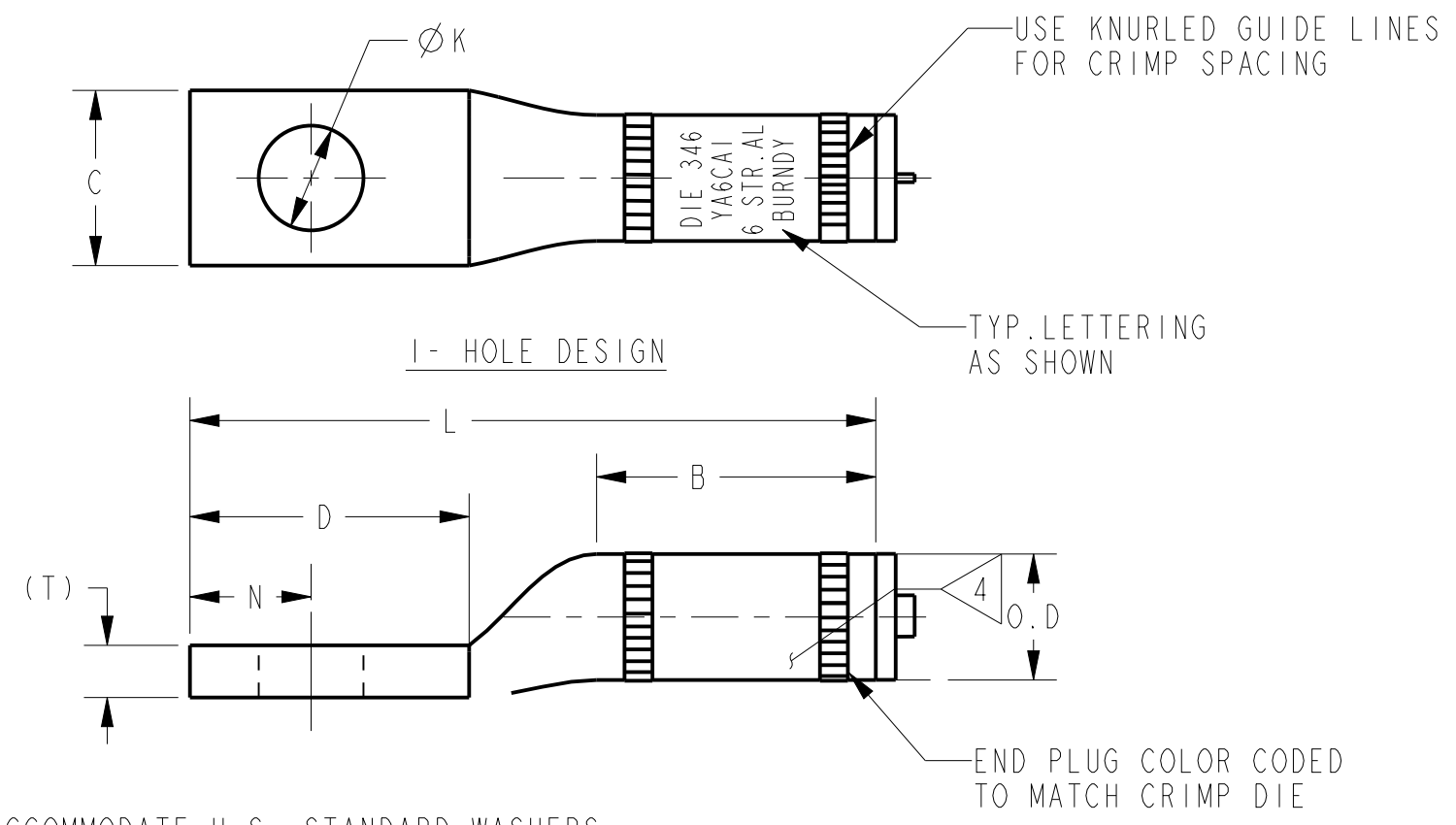

BARREL LETTERING VIEW

- NOTES:
- ALL HYLUGS™ ACCOMMODATE U.S. STANDARD WASHERS
 - REMOVE ALL EXCESS PENETROX™ FROM CONNECTOR AND ADJACENT CONDUCTOR PRIOR TO TAPING.
 - UL LISTED AND CSA CERTIFIED WIRE CONNECTORS. RATED 90 C (AL9CU) FOR USE WITH COPPER OR ALUMINUM CONDUCTOR. APPROVAL APPLY TO TIN PLATED CONNECTORS ONLY.
 - CONNECTOR BARRELS PREFILLED WITH PENETROX™
 - DIMENSIONS IN BRACKETS [] ARE IN MILLIMETERS ROUNDED OFF TO THE NEAREST MILLIMETER, UNLESS OTHERWISE NOTED, AND ARE FOR REFERENCE ONLY.
 - ADD SUFFIX "DT" TO ORDER LUGS WITH CRIMP BARREL SEALED AIR TIGHT INSIDE THE TRANSITION.
 - CATALOG #PT6515 ADAPTOR IS REQUIRED TO USE "U" DIES IN Y45 SERIES TOOLS.
 - CATALOG #PUADP-1 ADAPTOR IS REQUIRED TO USE "U" DIES IN Y46 SERIES TOOLS.
 - Y35P3 INDENTOR ADAPTOR REQUIRED FOR "Y34PR" TYPE INDENTORS.
 - FOR USE BY CUSTOMERS THAT HAVE THIS HYPRESS™. NO NEW HYPRESSES™ ARE BEING PROCESSED.
 - ADD SUFFIX "U" TO ORDER LUGS WITH UNDRILLED TONGUE.
 - ENLARGED BARREL MARKING VIEW.

UNINSULATED COMPRESSION TERMINAL MATERIAL: ALUMINUM TUBE

HYLUG™	
ITEM NO: NA	
CAT. NO: YA6CA-(SEE TABLE)	
DRAWN BY: E.S.K	7/19/72
CHECKER: S.F.P	8/01/72
DSN APPVL: R.B	8/02/72
MFG APPVL: --	--
QA APPVL: D.VARIO	6/19/95
MKT APPVL: P.WERTHMAN	6/19/95
PROD FAM: --	
PROJECT #: --	SIZE
DOCUMENT TYPE: Sales	C
REL LEVEL: Released	

DRAWING NO		SCALE: 2:1
SD073935	REV	
	SD073935	AJ
SHEET 2 OF 24		

REV: PE0200